

# 250D/T250D LOADERS



THE 250D SERIES LOADERS ARE AN EXCELLENT CHOICE  
ON THE DECK OR IN THE MILL YARD.

**Tigercat**<sup>®</sup>  
Tough • Reliable • Productive



THE 250D AND T250D ARE DESIGNED AND BUILT FOR HIGH PRODUCTION LOGGING OPERATIONS, HEAVY TIMBER AND TOUGH DUTY CYCLE DELIMBING APPLICATIONS.

### **EFFICIENT LOAD SENSING HYDRAULIC SYSTEM**

- ▶ Extremely fuel efficient for reduced merchandising and loading cost per tonne

### **DEDICATED, ENERGY RECOVERY SWING SYSTEM**

- ▶ Closed loop drive feeds power back to the engine when swing decelerates, reducing fuel consumption and recovering energy for other machine functions
- ▶ Dedicated swing system for quick cycles and enhanced machine performance in delimiting applications

### **HIGH CAPACITY SWING SYSTEM**

- ▶ Large diameter, high capacity bearing
- ▶ High torque starts and smooth stops

### **OPTIONAL SUPERDUTY (SD) PACKAGE, T250D**

- ▶ Long reach 11 m (36 ft) boom with live heel for mill yard applications



## POWERFUL STRENGTH-TO-WEIGHT OPTIMIZED BOOM

- ▶ Robust, well-protected cylinders and large diameter pins
- ▶ Designed for heavy lifting and high duty cycle delimiting

## WIDE STANCE, FOREST DUTY UNDERCARRIAGE, T250D

- ▶ Long track frames for excellent stability and flotation
- ▶ High clearance carbody and powerful tractive effort for excellent infield mobility
- ▶ Designed and built by Tigercat for full forest duty cycles

## RIGID, FABRICATED SUBFRAME, 250D

- ▶ Generously sized for excellent stability



## ACCESSIBILITY

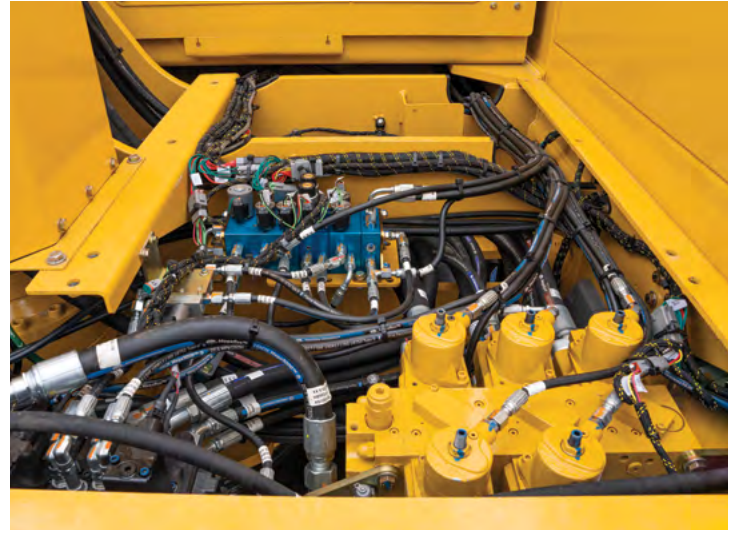

▶ Convenient platform access to the engine and daily service points. The compartment is neat and spacious

▶ All valves are located underneath the walk-up platform for clear and easy access with neat hydraulic and electrical routings



## A QUIET, SPACIOUS, ERGONOMIC OPERATING ENVIRONMENT

- ▶ Climate controlled air ride suspension seat reduces operator fatigue
- ▶ Fully adjustable, ergonomic seat, including seat pan fore/aft and tilt, and lumbar support positioning
- ▶ Adjustable armrests with comfortable armrest mounted controls
- ▶ Electronic control system with colour LCD touchscreen for machine monitoring and function adjustment





**EFFICIENT HYDRAULICS WITH A CLOSED LOOP SWING SYSTEM DELIVER SIMULTANEOUS POWER TO ALL MACHINE FUNCTIONS FOR HIGH PERFORMANCE, RESPONSE AND FUEL EFFICIENCY.**



### **OPTIONAL MILL YARD CAB RISER AND AC16 CARRIER**

For mill yard operations, the 155 cm (62 in) cab riser offers optimal visibility of the work area with a higher vantage point.

The AC16 articulating carrier is designed and built by Tigercat for mill yard applications. With forest duty axles and powerful tractive effort, the four-wheel drive AC16 handles rough mill yard terrain and towing applications with ease. Optional integrated bunks are also available.

**250D LOADER**

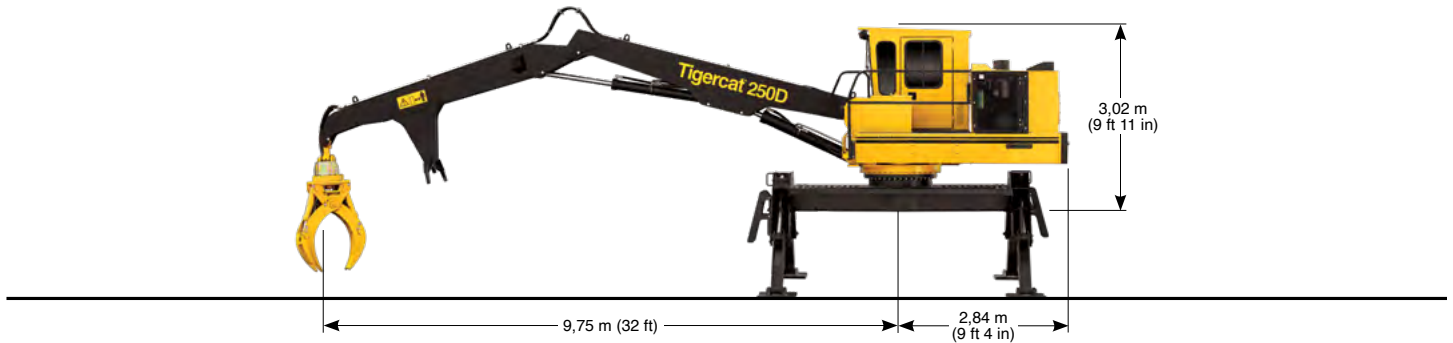

Scan the QR code then click 'SPECS' for a full list of machine specifications for the 250D Loader.

**T250D LOADER**

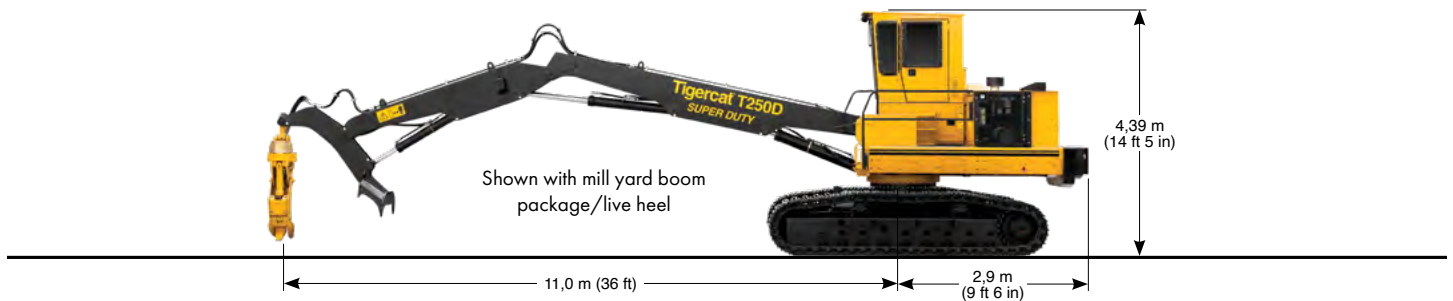

Scan the QR code then click 'SPECS' for a full list of machine specifications for the T250D Loader.

**Download the Tigercat App or visit [tigercat.com](http://tigercat.com) to access the most current machine specifications for all Tigercat machine models.**

<b>EMAIL</b>	comments@tigercat.com
<b>PHONE</b>	519.753.2000
<b>WEBSITE</b>	www.tigercat.com
<b>ADDRESS</b>	54 Morton Ave. East, Brantford, Ontario Canada, N3R 7J7
<b>MAIL</b>	Box 637 N3T 5P9